

HIGH POWER DIODE LASER

ALC-1370-4500-CB

The C-mount is an ideal component for quick prototyping and laboratory setups. However, the maximum output power is typically limited by the inherently sub-optimal heat dissipation properties of the C-mount itself.

Please contact us to discuss the best package option for your application.

Applications

- Medical
- Material Processing

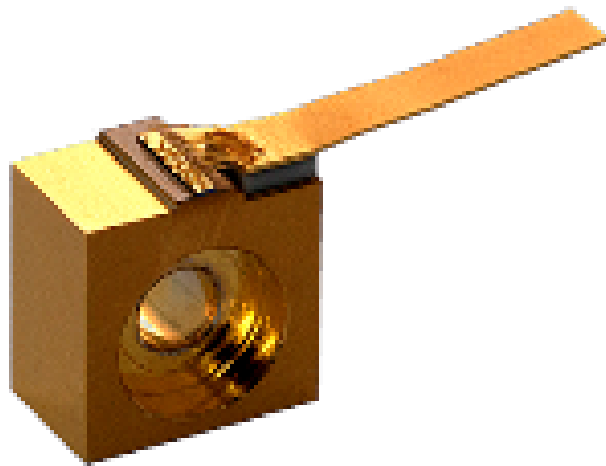

Specifications

Optical Parameters	Units	
Center Wavelength	nm	1370
Wavelength Tolerance	nm	±10
Spectral Width (FWHM)	nm	10.0
Wavelength Temp. Coefficient	nm/°C	0.5
Output Power	W	>4.5
Operating Current	A	9
Operating Voltage	V	<1.5
Threshold Current	A	0.7
Emitter width	µm	100
Beam divergence fast axis, FWHM	degrees	34
Beam divergence slow axis, FWHM	degrees	8

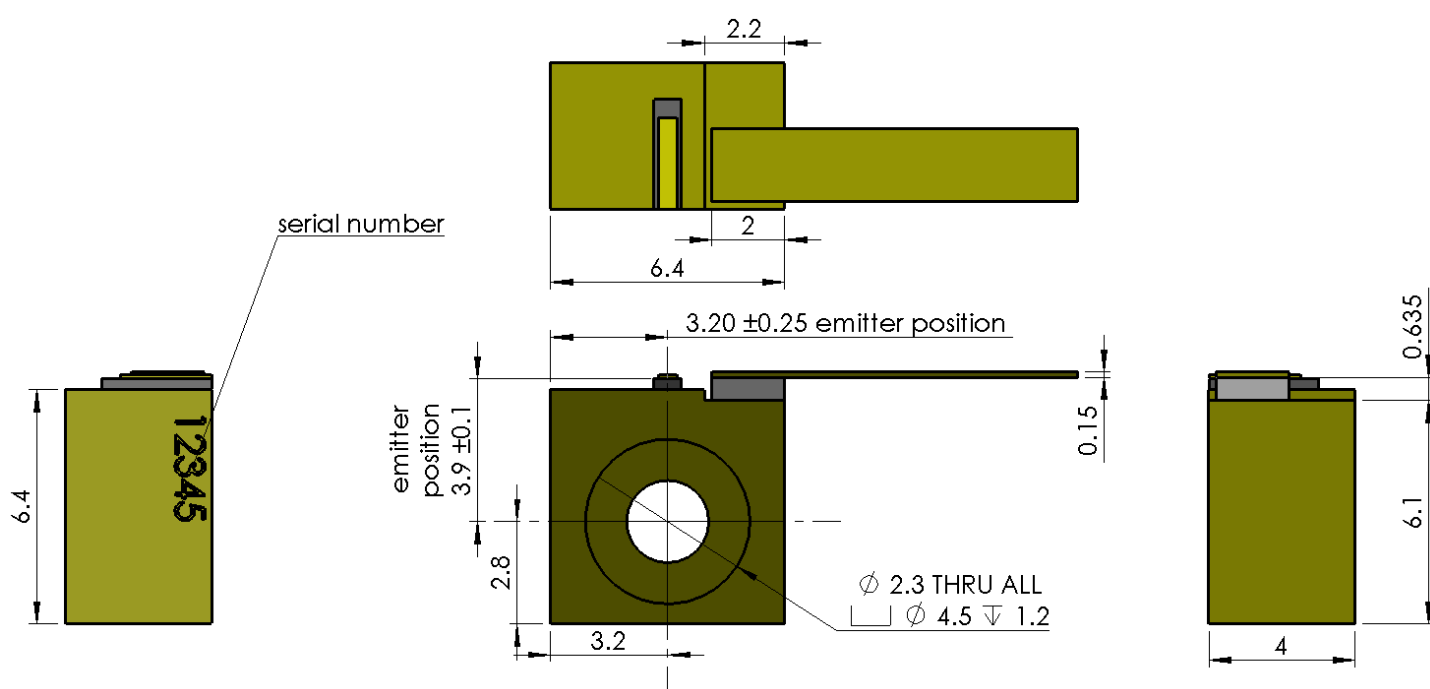
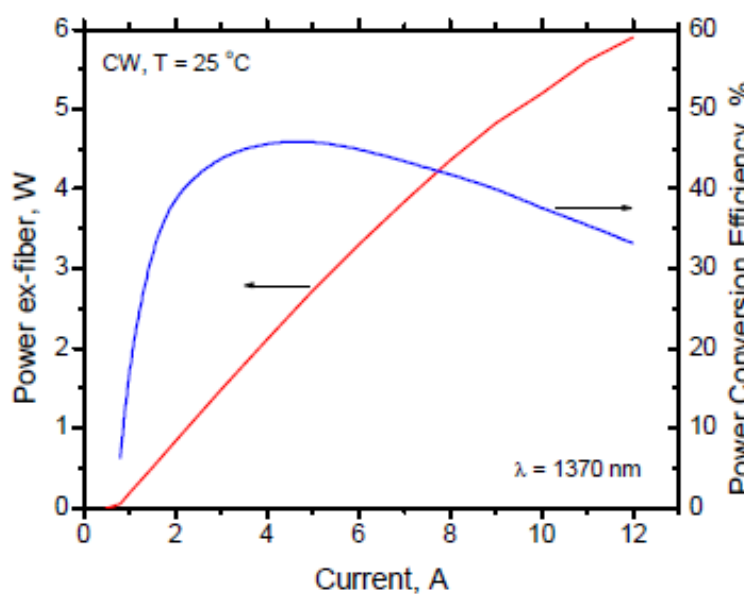

These components do not comply with the Federal Regulations (21 CFR Subchapter 1) as administered by the Center for Devices and Radiological health.

Purchaser acknowledges that his/her products must comply with these regulations before they can be sold.

Akela Laser Corporation reserves right to change any specifications

AKELA Laser Corporation

1095 Cranbury South River Road, Suite 14, Jamesburg, NJ 08831, USA
Phone: (732) 305-7105 e-mail: info@AKELALaser.com web: www.AKELALaser.com