

650 nm/ 664 nm/ 690 nm/ 730 nm Visible Laser Diode Data Sheet

AKELA's 650nm / 664nm / 690nm / 730nm laser diodes deliver an unmatched combination of output power, high-brightness and reliability from a single emitter. In addition to the c-mount, AKELA's visible diode laser product family is offered in three other free-space packages, as well as custom specified packages. An optional micro-lens collimates the fast axis to a divergence of less than 0.5 degrees. Please contact us to discuss your specific requirements.

Device Specifications	Minimum	Typical	Maximum
CW Output Power, W		2.0	2.5
Emitter Area, μm	100 x 1	100 x 1	100 x 1
Spectral Width (FWHM), nm	<1	<1	<1
Threshold Current, A	0.42	0.45	0.5
Slope Efficiency, W/A	0.75	0.80	0.85
EO Efficiency, %		28	30
Operating Current, A		3	4
Operating Voltage, V	2.0	2.3	2.5
Beam Divergence Fast Axis, $1/e^2$	50	50	50
Beam Divergence Slow Axis, 95%	7	7	7

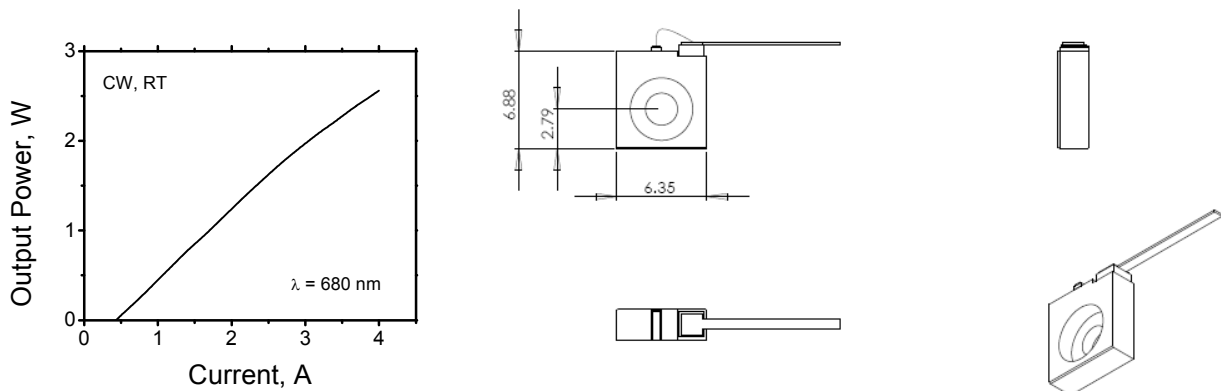

Specifications are subject to change without notice. In addition, AKELA can customize the laser design to meet different operating parameters. Please contact us for more details.

These components do not comply with the Federal Regulations (21 CFR Subchapter 1) as administered by the Center for Devices and Radiological health. Purchaser acknowledges that his/her products must comply with these regulations before they can be sold to a customer.