

1680 nm/ 1710 nm/ 1850 nm/ 1870 nm Laser Diode Data Sheet

AKELA's 1680nm / 1710nm/ 1850nm/ 1870nm laser diodes deliver an unmatched combination of output power, high-brightness and reliability from a single emitter. In addition to the c-mount, AKELA's single emitter diode laser product family is offered in three other free-space packages, as well as custom specified packages. An optional micro-lens collimates the fast axis to a divergence of less than 0.5 degrees. Please contact us to discuss your specific requirements, including different wavelengths.

Device Specifications	Minimum	Typical	Maximum
CW Output Power, W	2.0	2.2	2.7
Emitter Area, μm	100 x 1	100 x 1	100 x 1
Spectral Width (FWHM), nm	7	9	12
Threshold Current, A	0.7	1.0	1.3
Slope Efficiency, W/A	0.35	0.40	0.45
EO Efficiency, %	18	22	24
Operating Current, A	7.0	8.0	10
Operating Voltage, V	1.0	1.6	2.2
Beam Divergence Fast Axis, $1/e^2$	60	60	60
Beam Divergence Slow Axis, 95%	9	9	9

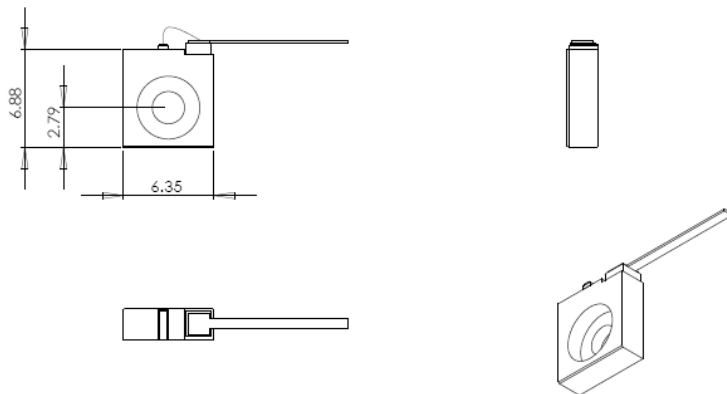
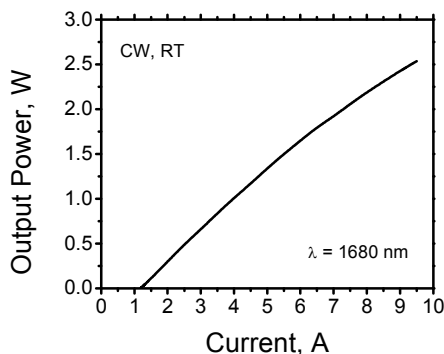

Specifications are subject to change without notice. In addition, AKELA can customize the laser design to meet different operating parameters. Please contact us for more details.

These components do not comply with the Federal Regulations (21 CFR Subchapter 1) as administered by the Center for Devices and Radiological health. Purchaser acknowledges that his/her products must comply with these regulations before they can be sold to a customer.